

**Serie s.CK kg 200, 500, 1000, 2500** .....

Approvazione (su richiesta) ATEX  II 1 G  II 2 D (zone 0-1-2-21-22) / on request ATEX approved (zone 0-1-2-21-22)

Realizzate in accordo alle norme OIML R60.  
Manufactured according to OIML R60 standards.



- ESECUZIONE ACCIAIO INOX 17-4 PH
- ERRORE COMBINATO  $\leq \pm 0,3 \%$
- GRADO DI PROTEZIONE IP 67
  
- STAINLESS STEEL 17-4PH CONSTRUCTION
- COMBINED ERROR  $\leq \pm 0.3 \%$
- PROTECTION RATING IP 67

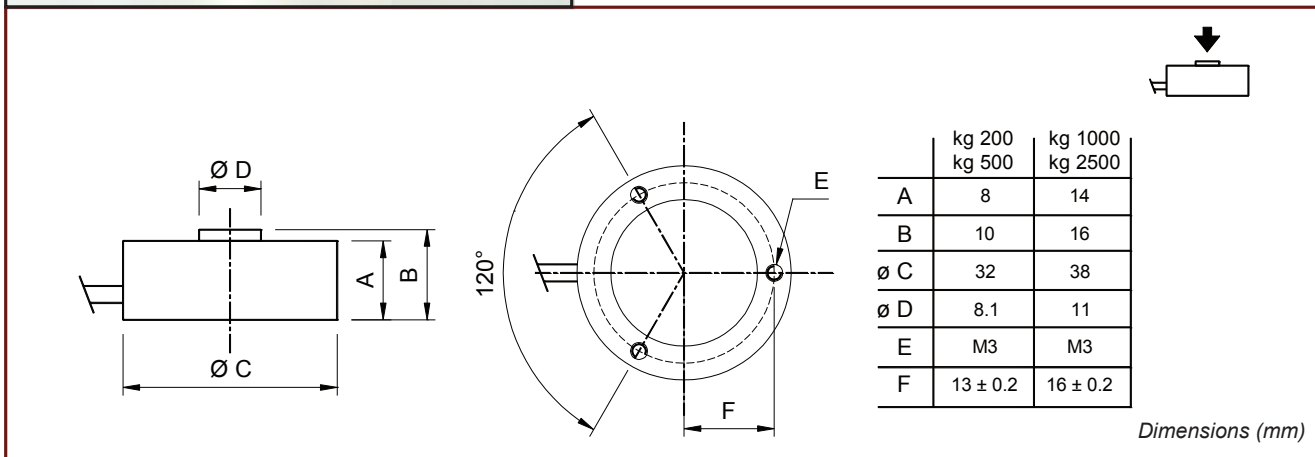

**CARATTERISTICHE TECNICHE**

SENSIBILITA'  
EFFETTO DELLA TEMPERATURA SULLO ZERO  
EFFETTO DELLA TEMPERATURA SUL FONDO SCALA  
COMPENSAZIONE TERMICA  
CAMPO DI TEMPERATURA DI LAVORO  
CREEP A CARICO NOMINALE DOPO 4 ORE  
TENSIONE DI ALIMENTAZIONE MAX TOLLERATA  
RESISTENZA D'INGRESSO  
RESISTENZA DI USCITA  
BILANCIAMENTO DI ZERO  
RESISTENZA D'ISOLAMENTO  
CARICO STATICO MASSIMO  
CARICO DI ROTTURA in % sul FONDO SCALA  
DEFLESSIONE A CARICO NOMINALE

1 mV/V +/- 10%  
0.005 % / °C  
0.005 % / °C  
- 10°C / + 50°C  
- 20°C / + 70°C  
0.3 %  
15 Volt  
400 Ohm +/- 100  
350 Ohm +/- 5  
+/- 1 %  
> 5000 MOhm  
120 %  
> 200 %  
0.3 mm

**TECHNICAL FEATURES**

SENSITIVITY  
TEMPERATURE EFFECT ON ZERO  
TEMPERATURE EFFECT ON SPAN  
COMPENSATED TEMPERATURE RANGE  
OPERATING TEMPERATURE RANGE  
CREEP AT NOMINAL LOAD AFTER 4 HOURS  
MAX SUPPLY VOLTAGE WITHOUT DAMAGE  
INPUT RESISTANCE  
OUTPUT RESISTANCE  
ZERO BALANCE  
INSULATION RESISTANCE  
MAXIMUM STATIC LOAD  
DESTRUCTIVE LOAD IN % ON FULL SCALE  
DEFLECTION AT NOMINLA LOAD

**CAVO**

LUNGHEZZA 5 m  
DIAMETRO 3 mm  
FILI CONDUTTORI 4 x 0.25 mm<sup>2</sup>

**CABLE**

LENGHT  
DIAMETER  
CORES



Spare s.r.l.  
Via Carlo Spagnolo, 4 - 27057 Varzi - Pavia - Italy  
tel. +39-0383-54.51.51 - fax: +39-0383-54.50.51  
<http://www.spare.it> - <http://www.spareonweb.com>  
e-mail: [sales@spare.it](mailto:sales@spare.it)